

EG4 Battery Power Wiring Diagrams

For EG4 Battery communications paralleling:

- 280 AH Outdoor All Weather WallMount Battery - refer to Section 8.1 in the MANUAL.
- 280 AH Indoor WallMount Battery - refer to Section 8.7 in the QUICK-START GUIDE.
- 100 AH WallMount Indoor Battery - refer to Section 8 of USER MANUAL.
- 100 AH Server Rack Batteries - Refer to sections 7.3 (48V), 7.1 (12/24V) of MANUAL.

Drawings Table of Contents:

Page 2

Table #1: UL9540 Approved EG4 ESS Inverter-Battery Combinations

Table #2: Recommended Minimum Battery/Inverter Ratios for EG4 ESS Systems

Wiring Diagram (Page # = Drawing #)

- 3) 1 x EG4 Hybrid or Off-Grid Inverter with 1-3 280 AH EG4 WallMount Batteries (Indoor or Outdoor)
- 4) 1 x EG4 Hybrid or Off-Grid Inverter with 4-6 280 AH EG4 WallMount Batteries (Indoor or Outdoor)
- 5) 1-3 x EG4 Hybrid or Off-Grid Inverters with 4-6 x 280 AH EG4 WallMount Batteries (Indoor or Outdoor)
- 6) Separating Batteries on Paralleled Inverters using the “Disable Battery Sharing” Setting
- 7) 1 or 2 EG4 Hybrid or Off-Grid Inverters with Server Rack Batteries - 1-2 Racks
- 8) 1 EG4 Hybrid or Off-Grid Inverters with Server Rack Batteries - 3 or more Racks
- 9) Multiple EG4 Hybrid or Off-Grid Inverters with Server Rack Batteries - 3 or more Racks

Table #1: Minimum Recommended Battery to Inverter Ratios for above ESS Systems.

Battery	WallMount		Server Rack	
	280 AH - 200 A BMS		100 AH - 100 A BMS	
	AllWeather	Indoor	LL-S 48V	LifePower4
EG4 Inverter				
12kPV	1	1	2.5	2.5
18kPV	1.5	1.5	4	4
FlexBoss18	1.5	1.5	4	4
FlexBoss21	1.5	1.5	4	4

This chart shows the minimum number of any EG4 batteries for any given EG4 Inverter in order for the inverter to supply it's full rated continuous power and surge rated power. Note that although the ESS chart below may indicate a lesser number of batteries per any given inverter is UL approved, this does not insure the inverter won't be throttled to a lower output by this smaller number of batteries. For instance using a single 280 AH battery with either the FlexBoss21 or the 18kPV will result in the 50 amp rating of the inverter being downgraded to 43 Amps. Consult your sales rep for the EG4 Battery and Inverter Sizing spreadsheet.

NOTE: For ESS System Model Numbers for all combinations of EG4 Inverters and Batteries see the website under Technical Support Bulletins for the document "EG4 ESS Model Number Explanation".

Table #2: EG4®ESS Inverter Battery Combinations with ETL conforming to UL9540

	FlexBOSS21	FlexBOSS18	18kPV-12LV	12kPV	12000XP	6000XP
EG4®-LL-48V100AH, LiFePO4 Battery*			1 inverter + 3-6 batteries 2 inverters + 6-12 batteries 3 inverters + 7-12 batteries	Pending		
EG4®LifePower4 48V 100AH, LiFePO4 Battery*			1 inverter + 3-6 batteries 2 inverters + 6-12 batteries 3 inverters + 7-12 batteries	Pending		
EG4® WallMount All Weather 48v 280Ah LiFePO4 Battery			1 inverter + 1-6 batteries 2 inverters + 2-6 batteries 3 inverters + 3-6 batteries			1 inverter + 1-6 batteries 2 inverters + 2-6 batteries 3 inverters + 3-6 batteries 4 inverters + 3-6 batteries
EG4® WallMount Indoor 48V 280Ah LiFePO4 Battery			1 inverter + 1-6 batteries 2 inverters + 2-6 batteries 3 inverters + 3-6 batteries			1 inverter + 1-6 batteries 2 inverters + 2-6 batteries 3 inverters + 3-6 batteries 4 inverters + 3-6 batteries

***Batteries must be mounted in server rack to comply with UL 9540**

Certificates are available in the ESS Systems descriptions at www.eq4electronics.com

3) One EG4 Hybrid or Off-Grid Inverter with 1-3 280 AH EG4 WallMount Batteries (Indoor or Outdoor)

1 Inverter and 1x280Ah WallMount Battery

1 Inverter and 2x280Ah WallMount Batteries

1 Inverter and 3x280Ah WallMount Batteries

EG4 Inverter with dual lug battery poles

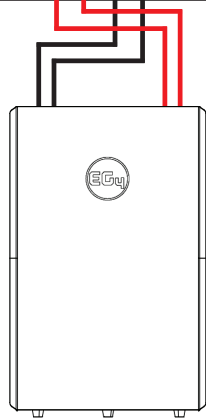
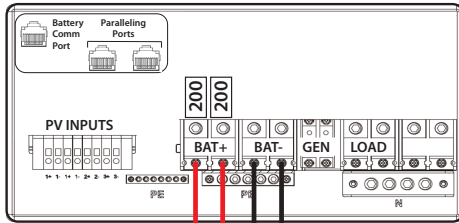

Protect all cable in metallic conduit or raceways. Exposed cables are unsafe and violate the NEC code.

EG4 Inverter with dual lug battery poles

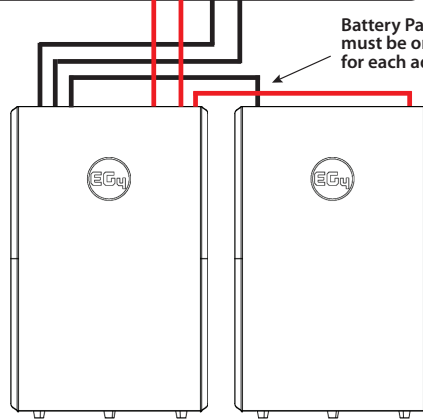
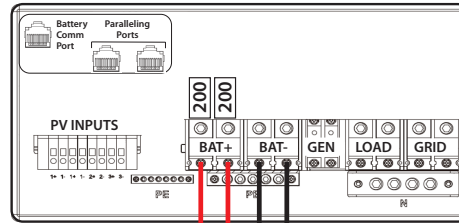

Battery Parallel Cabling Kit must be ordered separately for each additional battery.

EG4 Inverter with dual lug battery poles

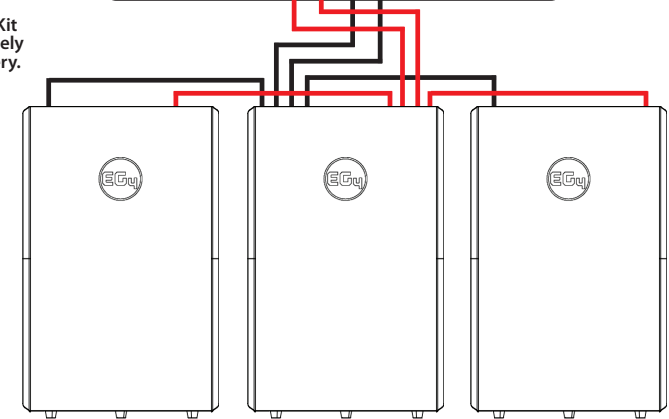
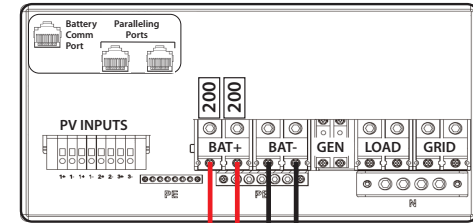

NOTE: The WallMount battery ships with one complete set of 4 cables (2 red, 2 black) for use between one battery and one inverter. For each additional battery, a paralleling kit must be purchased separately. For instances where the included cables are not sufficient length, custom cables can be ordered or made up using Degson connectors and crimp tools available at our suppliers. A maximum voltage drop of 2% is recommended for battery to battery and battery to inverter cabling. This means single sets of paralleling cables must be no longer than 20'. Dual cables can be used between batteries to decrease total voltage drop.

IMPORTANT NOTE:

The recommended minimum ratio of 280 AH WallMount batteries to number of 18kPV inverters is 1.5 to 1. SEE BATTERY TO INVERTER RATIO CHART ON PAGE 2. One battery - one inverter systems will work fine with the 18kPV inverter - performing close to - but not up to it's full rated capacity. The 18kPV can charge and discharge at a continuous 230 A rate whereas one 280AH WallMount battery can only accept or deliver 200 Amps max with a recommend continuous rating of 180 amps. With only one battery the 18kPV will have it's full 12,000 watts available for sell-back and to loads from PV and Battery combined but will be limited to 10,240 Watts max when using the battery only to power loads or sell back to the grid. When using one battery on one inverter we recommend setting the maximum charge and discharge settings to 180 Amps. Or strongly consider providing 2 batteries.

EG4 280 AH WallMount Batteries have internal paralleling bus bars rated to 600 Amps and internal breakers rated to 200 Amps per battery. The EG4 18kPV inverter also has 2 200 Amp Battery Breakers per positive battery terminal. No additional overcurrent protection is needed when paralleling up to 6 batteries and up to 2 inverters. Use the 2/0 battery cables included with the battery or with the paralleling kits and simply plug the cables in as shown. Make sure to use 2 runs of cables to each of the positive and negative inverter terminals.

4) One EG4 Hybrid or Off-Grid Inverter with 4-6 280 AH EG4 WallMount Batteries (Indoor or Outdoor)

NOTE: The WallMount battery ships with one complete set of 4 cables (2 red, 2 black) for use between one battery and one inverter. For each battery more than one battery per inverter, a paralleling kit must be purchased separately. For instances where the included cables are not sufficient length custom cables can be ordered or made up using Degson connectors and crimp tools available at our suppliers. A maximum voltage drop of 2% is recommended for battery to battery and battery to inverter cabling.

Cable Overcurrent Protection: EG4 280 AH WallMount Batteries have internal paralleling bus bars rated to 600 Amps and internal breakers rated to 200 Amps per battery. The EG4 18kPV inverter also has 2 200 Amp Battery Breakers per positive battery terminal. No additional overcurrent protection is needed when paralleling up to 6 batteries and up to 3 inverters as long as the sequence below is used. Use the 2/0 battery cables included with the battery or with the paralleling kits and simply plug the cables in as shown. Make sure to use 2 runs of cables to each of the positive and negative inverter terminals when connecting to the inverters. Do not separate batteries more than necessary.

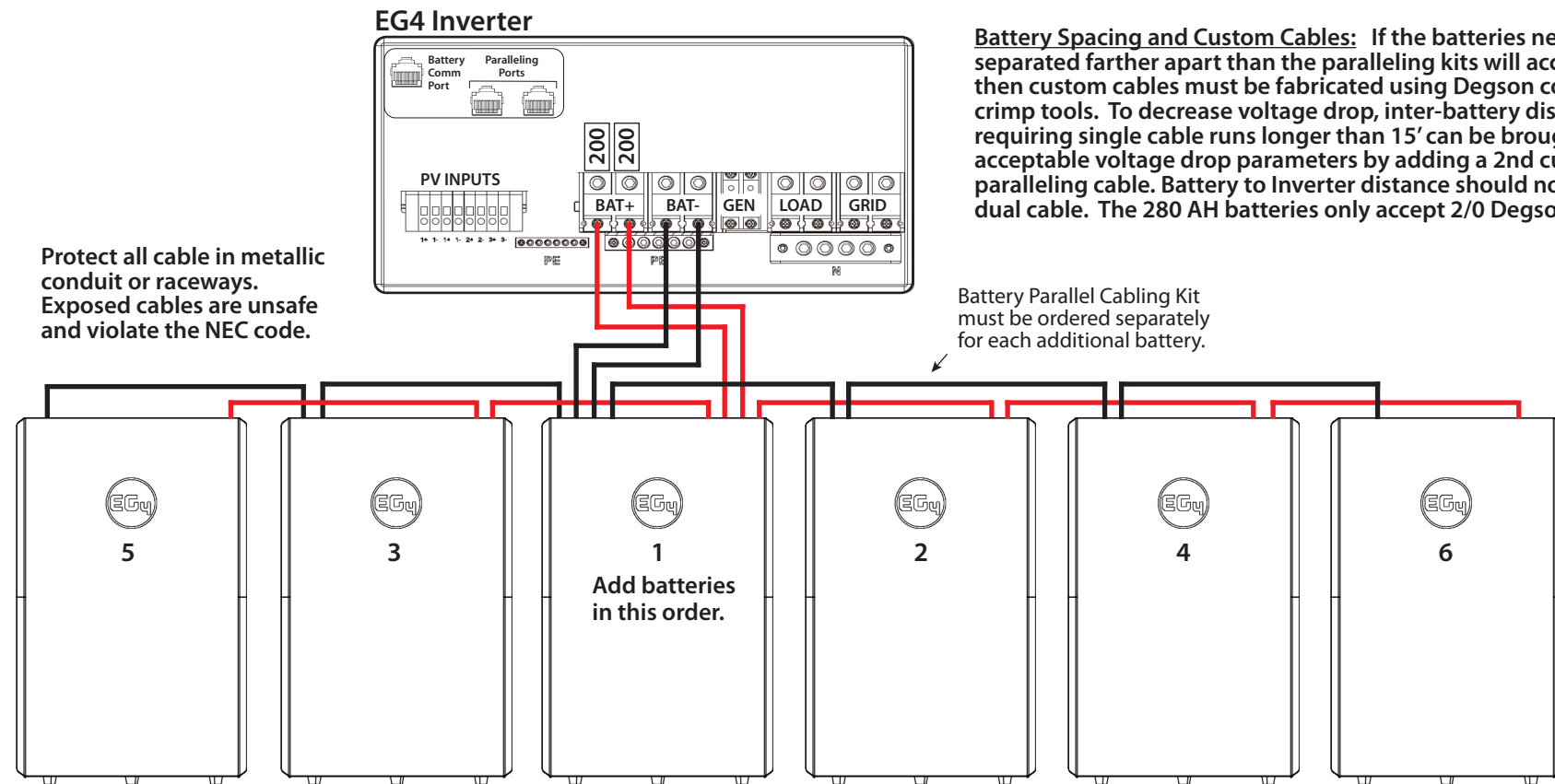

5) 1-3 x EG4 Hybrid or Off-Grid Inverters with 4-6 x 280 AH EG4 WallMount Batteries (Indoor or Outdoor)

Placement of Inverter & Battery Connections in Multi-Inverter Systems

Follow a logical order as much as possible according to the below graphic in order to achieve maximum performance, minimum voltage drop and minimum current on each cable. Single or dual inverter systems should not be placed on the “end” batteries in the parallel stack. For dual or triple inverter systems inverters may be placed on every other battery. IF BATTERIES CANNOT BE EQUALLY SPACED AND CO-LOCATED SEE NEXT PAGE FOR OPTIONS FOR “DISABLE BATTERY SHARING”.

Battery Spacing and Custom Cables: If the batteries need to be separated farther apart than the paralleling kits will accommodate, or that can be achieved using “Disable Battery Sharing” (see next page), then custom cables must be fabricated using Degson connectors and crimp tools. To decrease voltage drop, inter-battery distances requiring single cable runs longer than 15’ can be brought back within acceptable voltage drop parameters by adding a 2nd custom paralleling cable. Battery to Inverter distance should not exceed 20’ of dual cable. The 280 AH batteries only accept 2/0 Degson connectors.

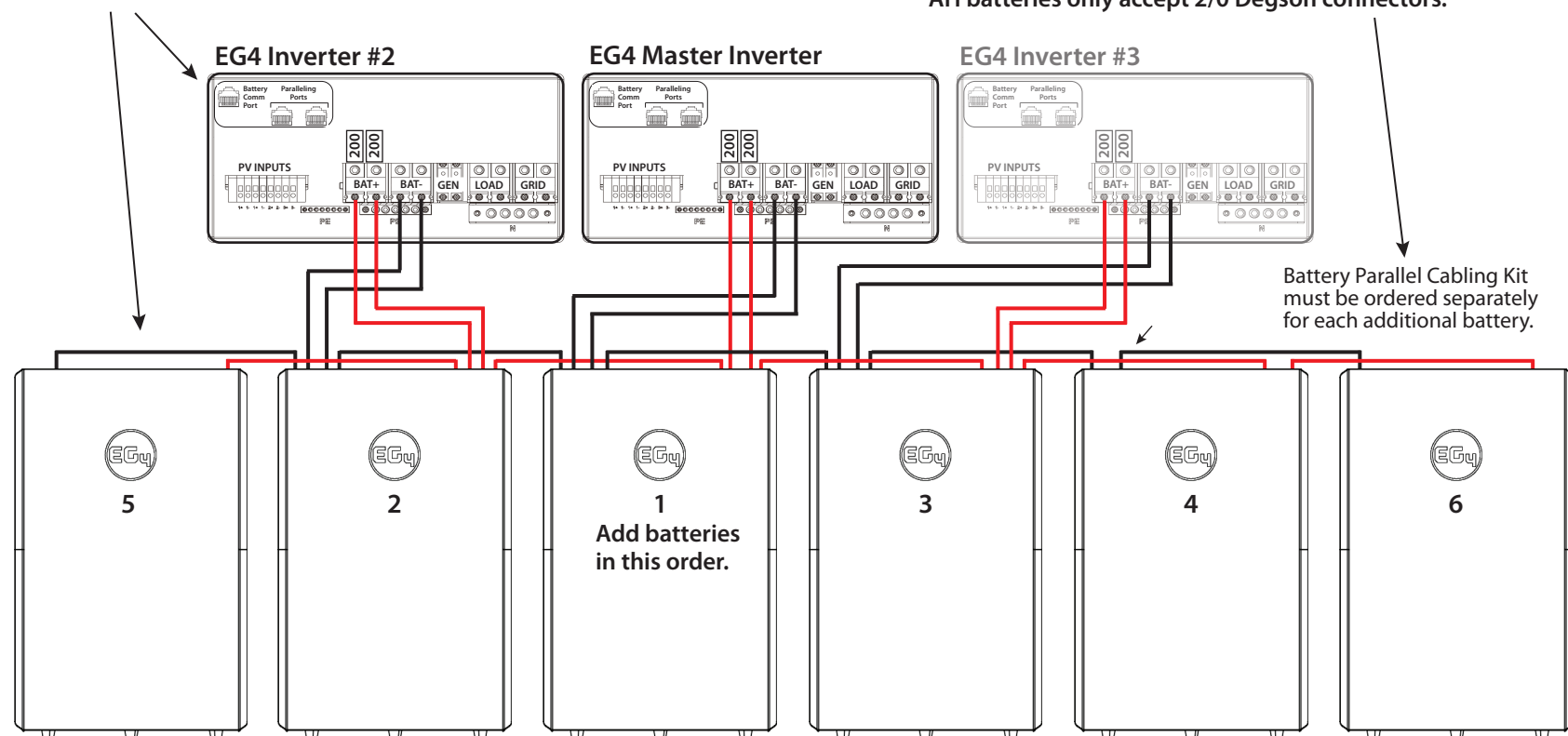

Cable Overcurrent Protection: EG4 280 AH WallMount Batteries have internal paralleling bus bars rated to 600 Amps and internal breakers rated to 200 Amps per battery. The EG4 18kPV inverter also has 2 200 Amp Battery Breakers per positive battery terminal. No additional overcurrent protection is needed when paralleling up to 6 batteries and up to 3 inverters as long as the sequence above is used. Use the 2/0 battery cables included with the battery or with the paralleling kits and simply plug the cables in as shown. Make sure to use 2 runs of cables to each of the positive and negative inverter terminals when connecting to the inverters. Do not separate batteries more than necessary.

IF BATTERIES NEED TO BE SEPARATED BY DISTANCES LARGER THAN CAN BE ACCOMMODATED BY THE PARALLEL KIT CABLES, CONSIDER PROVIDING 2 OR 3 EQUAL SETS OF BATTERIES TO PARALLELED INVERTERS USING THE “DISABLE BATTERY SHARING” SETTING - SEE NEXT PAGE.

6) Separating Batteries on Paralleled Inverters using the “Disable Battery Sharing” Setting

For multiple inverter systems with paralleled inverters, equal sets of batteries can be split between the inverters such that long parallel cable runs can be avoided using the “Disable Battery Sharing” setting. The inverters will keep the independent battery sets at roughly equal State of Charge (SOC). This can work with 2 equal sets on 2 inverters or 3 equal sets on 3 inverters.

EXAMPLE: 2 Paralleled Inverters and 4x280Ah Outdoor WallMount Batteries using “Disable Battery Sharing”

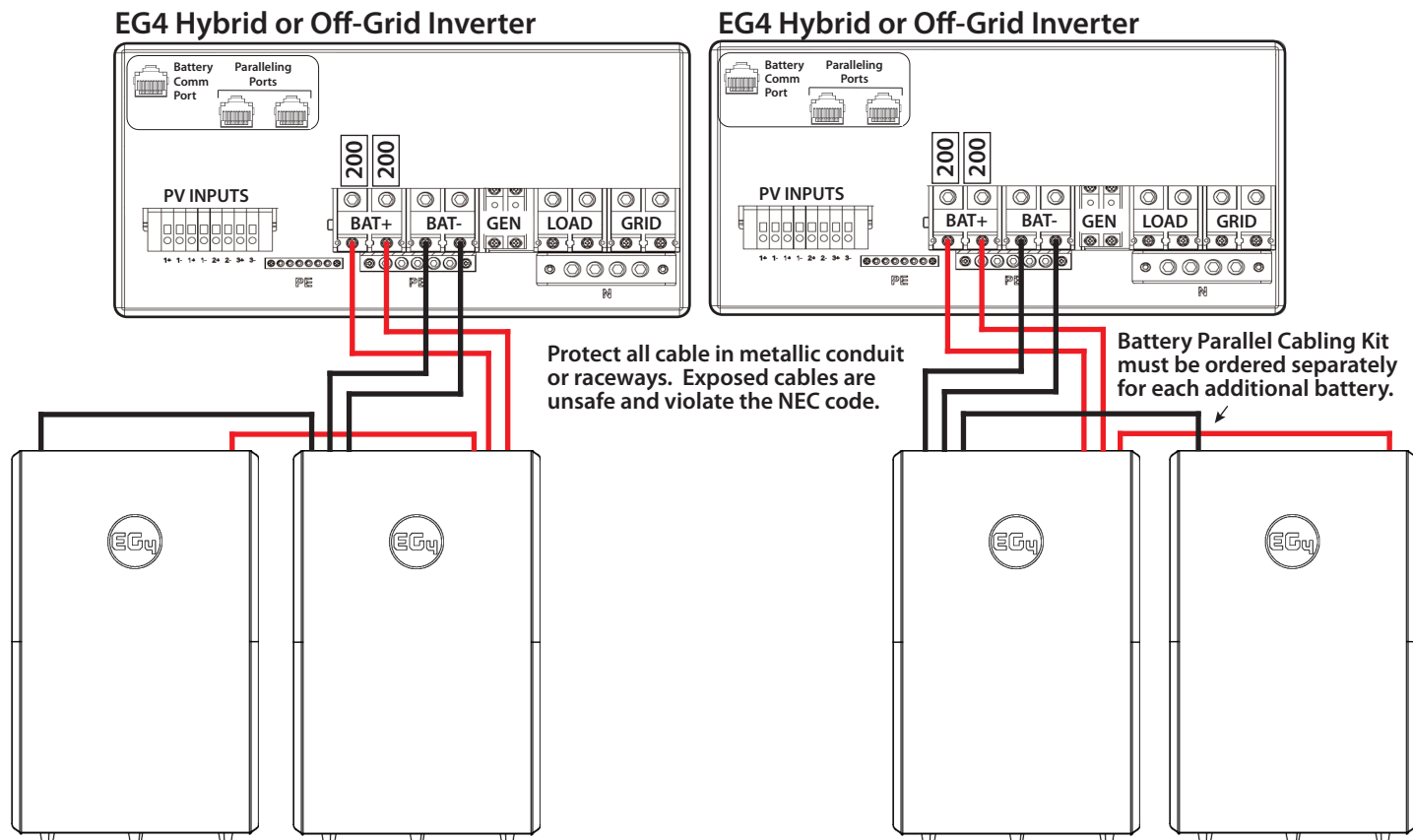

7) 1 or 2 EG4 Hybrid or Off-Grid Inverters with Server Rack Batteries - 1-2 Racks

1 Inverter and 1 Battery Rack

EG4 Hybrid or Off-Grid Inverter

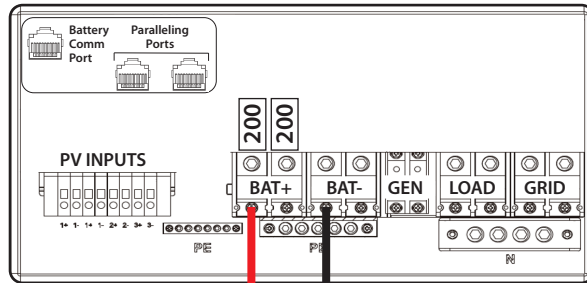

The 18kPV inverter has a max charge and discharge rate of 250 Amps and a continuous rating of 230 Amps. Therefore a minimum of 3 server rack, 100 AH batteries are recommended per 18KpV.

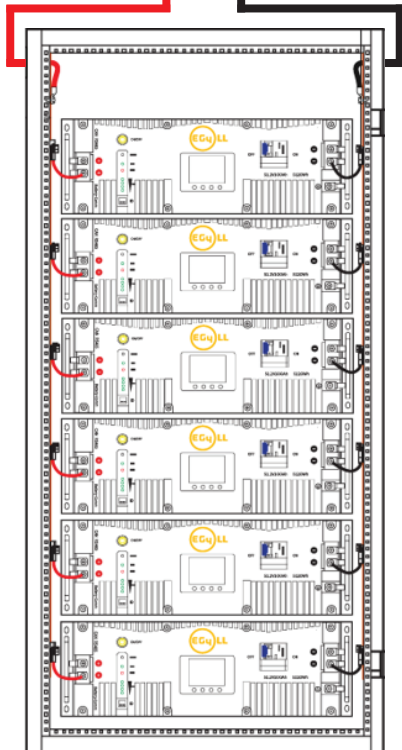

Built-in Battery and Inverter overcurrent protection coupled with battery BMS provides a good level of overcurrent protection for these two cases. The inverter has a two 200 Amp Battery Breakers - one on each positive terminal. Each Battery has a 100 Amp Breaker. Class T fuses can be added for full protection of the cable run from currents from both sides of the circuit. See 3-rack drawing. Consult with your AHJ for exact requirements. Each positive terminal needs a minimum of 2/0 cable. If using a single positive cable use 4/0 cable. Protect all cable in metallic conduit or raceways. Exposed cables are unsafe and violate the NEC code.

1 Inverter and 2 Battery Racks

EG4 Hybrid or Off-Grid Inverter

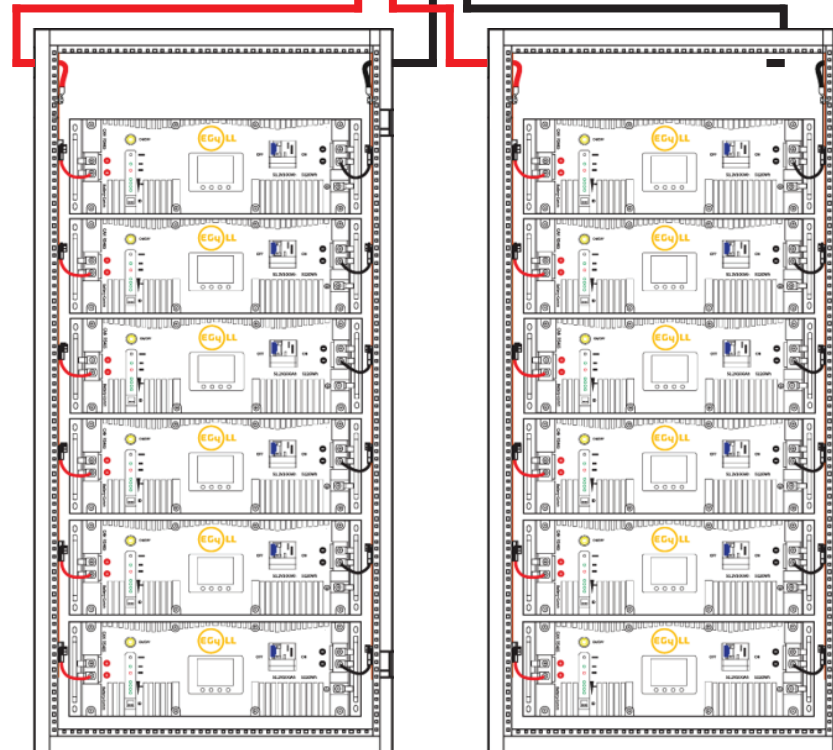
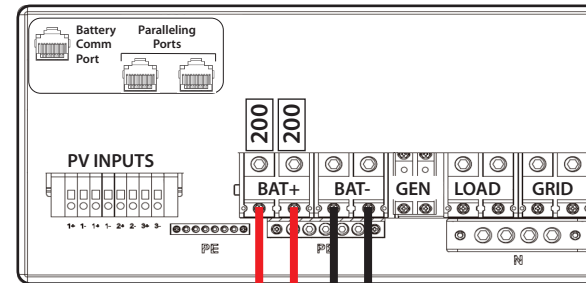

8) 1 EG4 Hybrid or Off-Grid Inverters with Server Rack Batteries - 3 or more Racks

The 18kPV inverter has a max charge and discharge rate of 250 Amps and a continuous rating of 230 Amps. Fuse protection on a bus bar ensures overcurrent protection for possible shorts between racks and rack cabling. Class T fuse are required to protect battery cabling per NEC Code.

EG4 Hybrid or Off-Grid Inverter

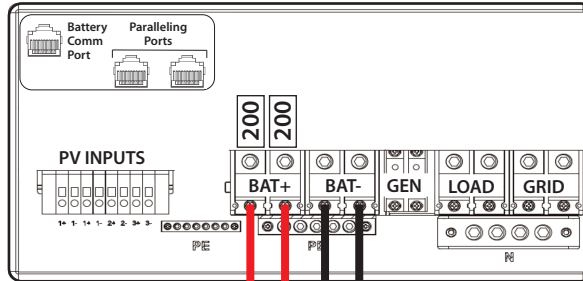

Protect all cable in metallic conduit or raceways. Exposed cables are unsafe and violate the NEC code.

Install Class T Fuse Blocks and Fuses. For 1 inverter and 3 server rack systems we recommend using 2 runs of 2/0 cable between bus bar and inverter with individual 200 Amp fuses per run.
(Blue Seas Systems 5007100 and Littelfuse JLLN200, or equivalent)

Install Class T Fuse Blocks and Fuses. For 1 inverter and 3 server rack systems we recommend 2/0 cable between rack bus bars and positive bus bars with 200 Amp fuses. This will prevent cascading nuisance tripping in the event that one fuse blows.

Use 600 Amp Rated Positive and Negative Bus Bars (Blue Seas Systems 2104 PowerBar, 600A, 4x3/8"-16 Studs, or equivalent).

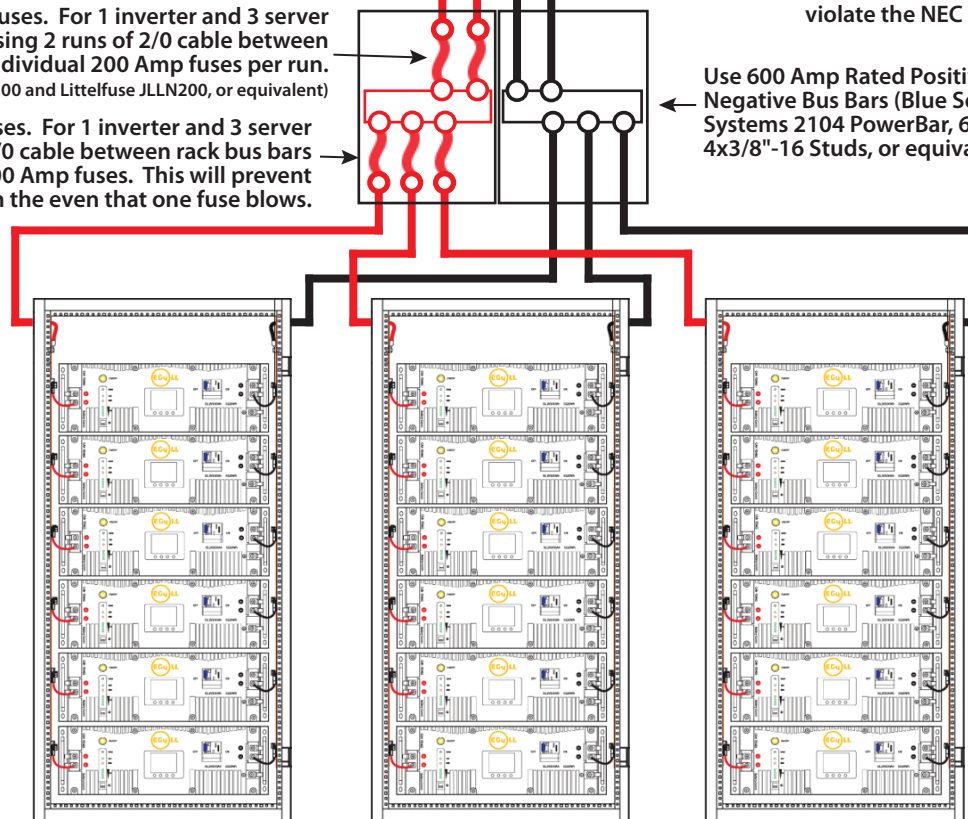

Each Battery is protected by a 100 A DC Breaker and a 100 Amp BMS that detects short circuits.

9) Multiple EG4 Hybrid or Off-Grid Inverters with Server Rack Batteries - 3 or more Racks

Each 18kPV inverter has a max charge and discharge rate of 250 Amps and a continuous rating of 230 Amps. Fuse protection on a bus bar ensures overcurrent protection for possible shorts between racks and rack cabling. Class T fuse are required to protect battery cabling per NEC Code..

EG4 Hybrid or Off-Grid Inverter

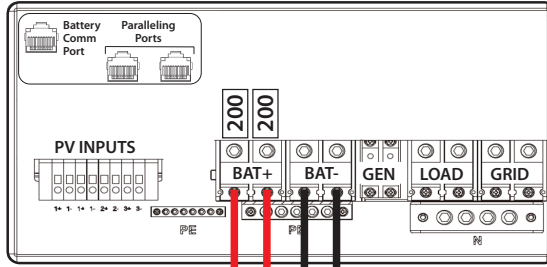

EG4 Hybrid or Off-Grid Inverter

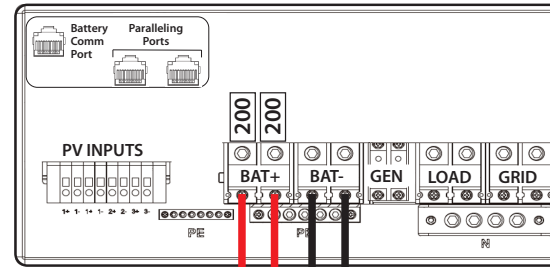

Protect all cable in metallic conduit or raceways. Exposed cables are unsafe and violate the NEC code.

Install Class T Fuse Blocks and Fuses. For 1 inverter and 3 server rack systems we recommend using 2 runs of 2/0 cable between bus bar and inverter with individual 200 Amp fuses per run. (Blue Seas Systems 5007100 and Littlefuse JLLN200, or equivalent)

Install Class T Fuse Blocks and Fuses. For 2 inverter and 4 server rack systems we recommend 2/0 cable between rack bus bars and positive bus bars with 200A fuses. This will prevent cascading nuisance tripping in the even that one fuse blows.

Use 600 Amp Rated Positive and Negative Bus Bars (Blue Seas Systems 2104 PowerBar, 600A, 4x3/8"-16 Studs, or equivalent).

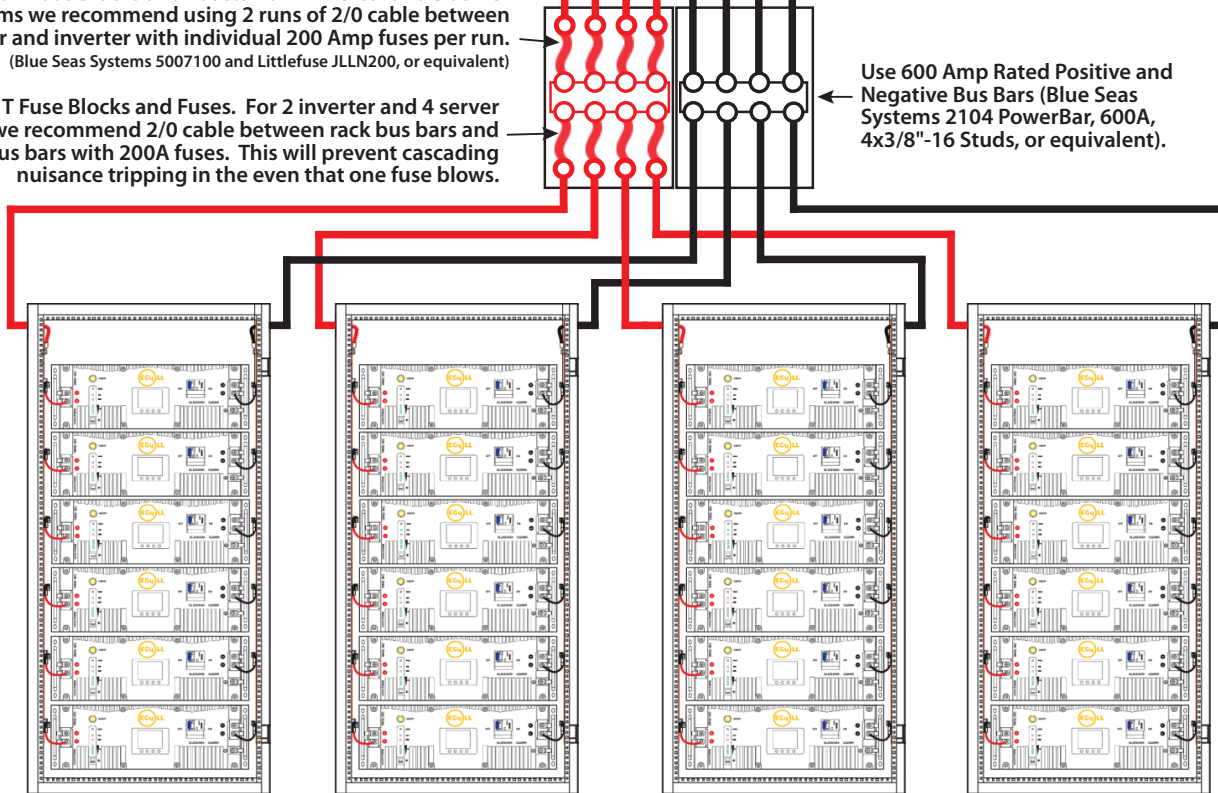

Each Battery is protected by a 100 A DC Breaker and a 100 Amp BMS that detects short circuits.